

## SUBMERSIBLE PUMPS

### OLIJU BA GUIDE RAIL KIT-STOOL, CLAW & TOP BRACKET

**E**

The guide rail facilitates maintenance operations allowing to remove the pump without draining the tank. BA series come with female threads and may require a nipple to connect the pump to the claw depending on the pump model.

#### Features

2"  
2½"  
3"

#### Applications

Heavy Duty  
Sewage Vessels

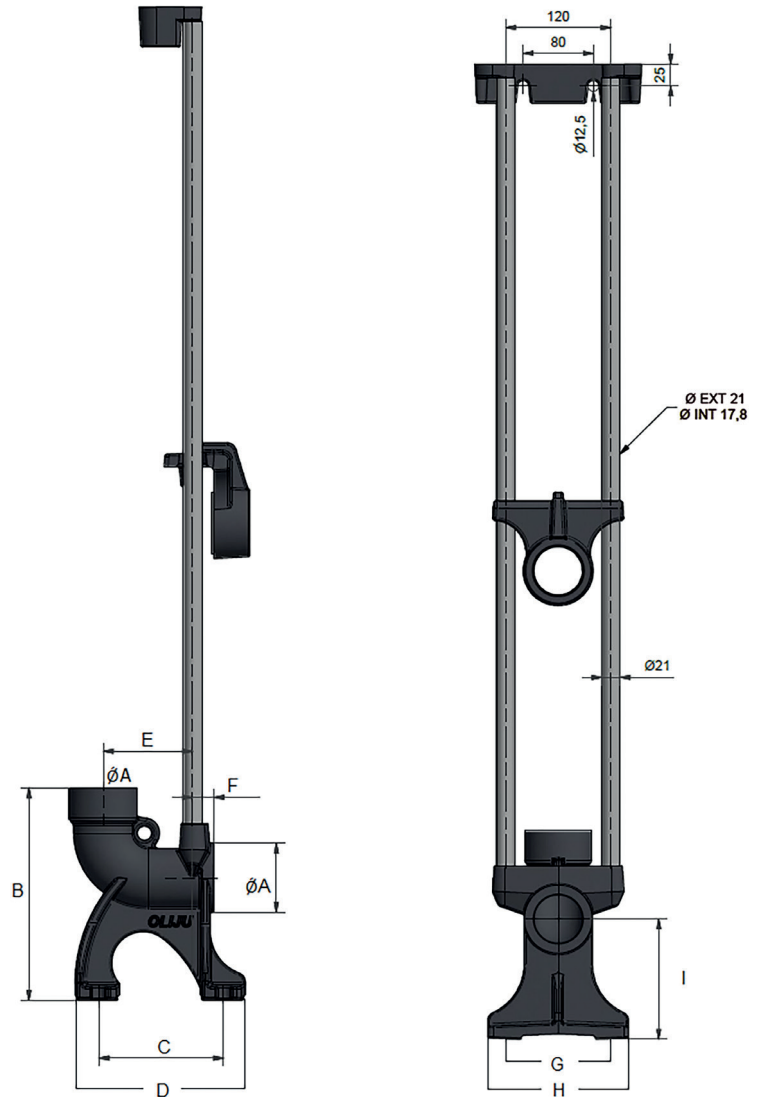

TYPE	DIMENSIONS (mm)								
	ØA	B	C	D	E	F	G	H	I
BA 50	2"	235	140	190	100	63	130	160	135
BA 65	2½"	285	166	220	119	68	150	180	165
BA 80	3"	298	174	229	119	68	180	210	175

MODEL	OUTLET	Kg	CODE
BA 50	2"	9.5	1200-0402
BA 65	2½"	13	1200-0406
BA 80	3"	15	1200-0408
SGR 40 ADAPTER TO SUIT BA50	2"	1.9	1200-0420